



*Danchuk 18171*

**REMASTER INSTALLATION INSTRUCTIONS**

Instruction Part Number: 6000510 | Product: Remaster 1 1/2" Master Cylinder  
Ford and GM - Both Firewall and Booster bolt patterns

**ATTENTION: Read this before going any farther!**  
Returns will not be accepted for ANY installed PART or ASSEMBLY.

Notices – Read and Follow BEFORE ATTEMPTING INSTALLATION

All installations require proper safety procedures and protective eyewear. All installations assume basic mechanical skill and a factory service manual for the vehicle on which the installation is to be performed. Pushrod depth (from mounting surface to bottom of piston) is .990"

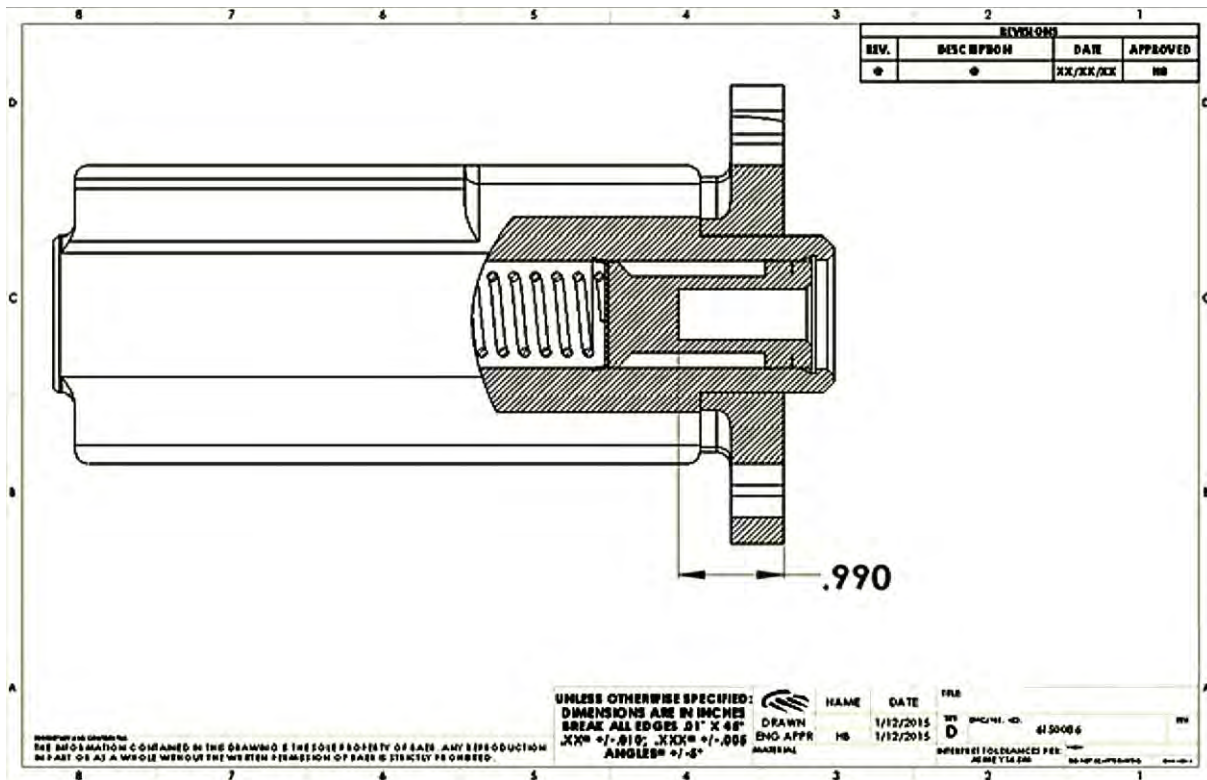

- | For early Fords this dimension is correct but should still be checked as they may have been changed over time.
- | For Fox/SN95 (79-04 Mustang) the booster pushrod is .950" so it would need to be adjusted out .040". The booster pushrods on these Bendix units are adjustable.
- | The clearance between the pushrod and REMASTER piston should be .000"-.005". Too little and the brakes may drag, too much and the pedal will have excessive travel.



GM boosters used short and long pushrods to actuate the master cylinder. If you have a short pushrod booster, insert the supplied bullet as shown in photo 1 below.



For a standard 3/8-24 tube nut and line, install the brass fittings shown.

Banjo style fittings installed on REMASTER. Copper washers placed on both sides of banjo fittings. Do not use brass seats for banjo style fittings! Tighten tube nuts or banjo bolts to 10-12 ft-lbs.

Service Note: The brass inserts also allow the seats to be replaced if damaged without needing to replace the master cylinder. Contact your Baer Tech Rep. for replacement procedures and new seats.



For manual brakes adjust the pushrod so the pedal does not travel over center (past 90 degrees) when depressed. The drawing below shows proper travel.

The drawing on the left illustrates proper release and applied travel. The drawing on the right shows the pedal traveling past 90 degrees. Adjust the pedal length to prevent travel past 90 degrees.



Correct pedal travel

Pedal applied traveling past 90 degrees