

ALUMINUM TANDEM MASTER CYLINDER

SPECIFICATION SHEET • INSTRUCTIONS

Master Cylinder Part Numbers
260-8555/-P/-BK • 260-8556/-P/-BK
260-9439/-P/-BK • 260-13375/-P/-BK



Bright Finish Shown

Component	Specifications
Piston / Bore Diameter	7/8, 15/16, 1 & 1-1/8 inches
Piston Stroke / Push Rod Travel	1.10 inches
Volume Output Ratio (A/B)	2:1
Pressure Output Ratio (A/B)	50 / 50
Reservoir Capacity: Primary (A)	13.93 Cubic inches
Secondary (B)	8.43 Cubic inches

Danchuk 18550-18551-18552-18553-18554-18555

WARNING

IT IS THE RESPONSIBILITY OF THE PERSON INSTALLING ANY BRAKE COMPONENT OR KIT TO DETERMINE THE SUITABILITY OF THE COMPONENT OR KIT FOR THAT PARTICULAR APPLICATION. IF YOU ARE NOT SURE HOW TO SAFELY USE THIS BRAKE COMPONENT OR KIT, YOU SHOULD NOT INSTALL OR USE IT. DO NOT ASSUME ANYTHING. IMPROPERLY INSTALLED OR MAINTAINED BRAKES ARE DANGEROUS. IF YOU ARE NOT SURE, GET HELP OR RETURN THE PRODUCT. YOU MAY OBTAIN ADDITIONAL INFORMATION AND TECHNICAL SUPPORT BY CALLING WILWOOD AT (805) 388-1188, OR VISIT OUR WEB SITE AT WWW.WILWOOD.COM. USE OF WILWOOD TECHNICAL SUPPORT DOES NOT GUARANTEE PROPER INSTALLATION. YOU, OR THE PERSON WHO DOES THE INSTALLATION MUST KNOW HOW TO PROPERLY USE THIS PRODUCT. IT IS NOT POSSIBLE OVER THE PHONE TO UNDERSTAND OR FORESEE ALL THE ISSUES THAT MIGHT ARISE IN YOUR INSTALLATION.

RACING EQUIPMENT AND BRAKES MUST BE MAINTAINED AND SHOULD BE CHECKED REGULARLY FOR FATIGUE, DAMAGE, AND WEAR.

Installation Notes and Precautions

- Check the length and diameter of the push rod from the pedal or power booster. It should fully engage the bottom of the recess in the master cylinder piston assembly without interference along the sides or shoulders. For short push rod power brake boosters, use the spacer supplied to reduce the overall depth of the piston recess. The piston detail diagram on page 2 illustrates the overall depth and diameter of the push-rod recess.
- When the pedal is released, the piston assembly must fully return to the snap-ring retainer at the end of the cylinder bore. Consequently, the push rod must be long enough to remain captured inside the piston recess when the pedal is fully retracted. Adjust the length of the push rod and available pedal travel as necessary. Return springs and pedal stops are always recommended.

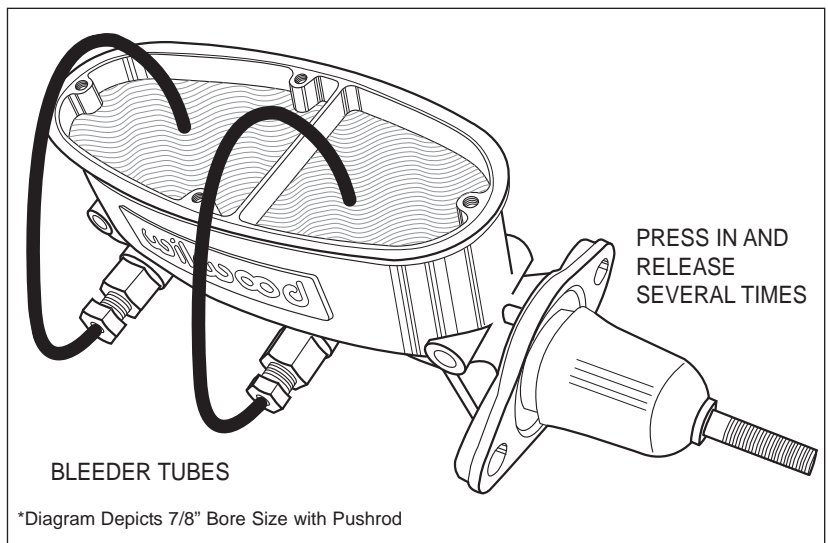

Typical Bleeder Tube Setup and Use

WARNING

THIS COMPONENT IS DESIGNED FOR USE IN CUSTOM BRAKE SYSTEMS ON PERFORMANCE, RACING, AND OTHER SPECIAL PURPOSE BUILT OFF-ROAD VEHICLES. IT IS NOT INTENDED AS A DIRECT REPLACEMENT FOR ANY OEM APPLICATION.

- Always mount the master cylinder to a secure, reinforced element of the chassis. There should be no movement or deflection at the mount point when brake pedal pressure is applied.

- Prior to attaching the fluid lines, fill the reservoirs with Wilwood fluid from a new, sealed container and purge any air from the master cylinder. Be sure the cylinder is level during the bleeding operation. If the cylinder is not level when mounted in the vehicle, you can perform this operation prior to attaching the master cylinder to its mount. The diagram illustrates one method of recycling the fluid into the reservoir until all air has been eliminated. Exercise care to not spill or spray brake fluid. Take all proper safety precautions including eye and skin protection and do not position your face directly above the reservoir. This process will assure a quick and effective full system bleed later.

- Once all fluid connections have been made, the complete system must be bled and checked for leaks prior to any test of the vehicle.

Plumbing Notes and Precautions

- Each master cylinder kit includes one 9/16-18, one 1/2-20, and two 3/8-24 inverted flare threaded line adapters for connections to the brake lines (Adapters are not installed and are shipped in the reservoir of the master cylinder, remove lid to access). Two hex head plugs are supplied to block the unused outlet ports. Pressure may be taken from either side of the master cylinder. After selecting the size and location of the outlet ports to be used, lubricate adapter fitting threads lightly with silicone or lithium based grease, then install the fittings and plugs, using the aluminum crush washers and torque each to 20-25 foot pounds.
- The line adapters supplied with each master cylinder are for use with double flared brake line. Use only double flared lines. Do not attempt to use single flared connections. Do not use additional sealant or any other type of gaskets on the fittings, lines, or plugs.
- Connect one of the primary outlet ports (A) to the brakes at the end of the vehicle with the greatest total effective piston bore area. On most vehicles, this will be the front brake line (see note next page).
- Connect one of the secondary outlet ports (B) to the brakes at the end of the vehicle with the lesser total effective piston bore area. On most vehicles, this will be the rear brake line (see note next page).
- Use of reinforced flexible lines should be limited to the connection between the fixed chassis and the moving suspension. All other lines along the fixed chassis should be hard steel lines.
- On four wheel disc brake applications, where the fluid reservoir is mounted higher than the caliper bleed screws, a residual pressure valve is usually not required.
- On disc brake applications where the fluid reservoir is mounted lower than the caliper bleed screws may require a 2 pound residual pressure valve. This can prevent fluid drain back and excessive pedal travel on initial engagement.
- All drum brake applications require an inline 10 pound residual pressure valve.
- Use an adjustable proportioning valve to set the front to rear brake bias.

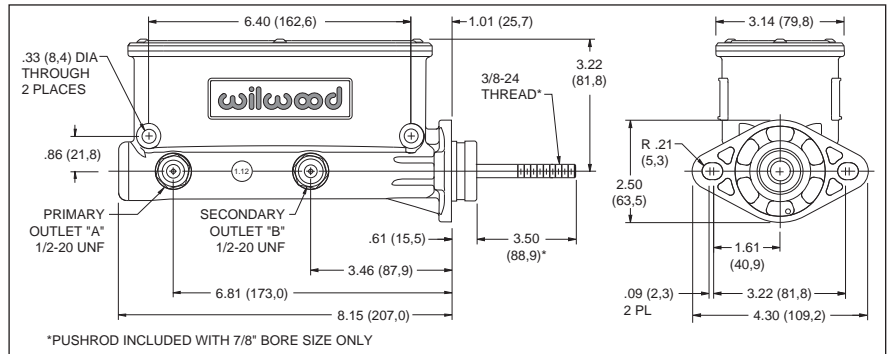

Wilwood Dual Outlet Tandem Chamber Master Cylinder, Mounting Dimensions

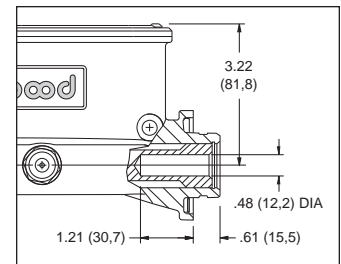

Piston Detail • 1" and 1-1/8" Bore Master Cylinders Only

REBUILD NOTE:

WILWOOD TANDEM MASTER CYLINDERS ARE NOT USER SERVICEABLE DUE TO THE NECESSITY OF SPECIAL TOOLS FOR DISASSEMBLY. IN THE EVENT REBUILDING SERVICE IS REQUIRED, PLEASE CONTACT WILWOOD TECHNICAL DEPARTMENT AT (805) 388-1188 TO ARRANGE FOR RETURNING MASTER CYLINDER FOR FACTORY REBUILD AND/OR REPAIR AT A NOMINAL COST.

CALCULATING EFFECTIVE PISTON BORE AREA TO DETERMINE PLUMBING

To determine the effective piston bore area of any caliper, you must first calculate the area for each piston bore found on one side of the caliper. Use the formula "Area = (bore x bore) x .785" for each piston bore size. Then, add the areas of all pistons on that one side of the caliper to determine the total effective piston bore area. Compare the difference between the front and rear calipers and attach the line from the primary outlet "A" to the calipers at the end of the vehicle with the greater total effective piston bore area.

Tandem Master Cylinders

<u>Part No.</u>	<u>Description</u>	<u>Part No.</u>	<u>Description</u>
260-9439	7/8" Bore M/C - Standard Finish	260-13375	15/16" Bore M/C - Standard Finish
260-9439-P	7/8" Bore M/C - Bright Finish	260-13375-P	15/16" Bore M/C - Bright Finish
260-9439-BK	7/8" Bore M/C - Black Finish	260-13375-BK	15/16" Bore M/C - Black Finish
260-8555	1" Bore M/C - Standard Finish	260-8556	1-1/8" Bore M/C - Standard Finish
260-8555-P	1" Bore M/C - Bright Finish	260-8556-P	1-1/8" Bore M/C - Bright Finish
260-8555-BK	1" Bore M/C - Black Finish	260-8556-BK	1-1/8" Bore M/C - Black Finish

Components and Accessories

<u>Part No.</u>	<u>Description</u>	<u>Part No.</u>	<u>Description</u>
260-1874	2 PSI Residual Pressure Valve	290-0632	Wilwood Hi-Temp 570 DOT 3 Fluid
260-1876	10 PSI Residual Pressure Valve	290-6209	Wilwood EXP 600 Plus Super Hi-Temp Fluid
260-8419	Knob Adjustable Proportioning Valve		
260-8420	Lever Adjustable Proportioning Valve		

WARNING • DO NOT DRIVE ON UNTESTED BRAKES BRAKES MUST BE TESTED AFTER INSTALLATION OR MAINTENANCE MINIMUM TEST PROCEDURE

- Make sure pedal is firm: Hold firm pressure on pedal for several minutes, it should remain in position without sinking. If pedal sinks toward floor, check system for fluid leaks. DO NOT drive vehicle if pedal does not stay firm or can be pushed to the floor with normal pressure.
- At very low speed (2-5 mph) apply brakes hard several times while turning steering from full left to full right, repeat several times. Remove the wheels and check that components are not touching, rubbing, or leaking.
- Carefully examine all brake components, brake lines, and fittings for leaks and interference.
- Make sure there is no interference with wheels or suspension components.
- Drive vehicle at low speed (15-20 mph) making moderate and hard stops. Brakes should feel normal and positive. Again check for leaks and interference.
- Always test vehicle in a safe place where there is no danger to (or from) other people or vehicles.
- Always wear seat belts and make use of all safety equipment.